

Katalog złączy hydrauliki siłowej

Spis treści

Kod	Nazwa artykułu	Str.
O 1/2SN	Oprawka / tuleja do węży 1SN-R1AT-2SN-R2AT-2SC	3
O 4SP	Oprawka / tuleja do węży 4SP	3
O 4SH	Oprawka / tuleja do węży 4SH	3
DKOL	Końcówki proste z nakrętką gwint metryczny – odmiana lekka	4
DKOL90	Końcówki kątowe 90° z nakrętką gwint metryczny – odmiana lekka	4
DKOL45	Końcówki kątowe 45° z nakrętką gwint metryczny – odmiana lekka	5
CEL	Końcówki proste gwint zewnętrzny metryczny – odmiana lekka	5
DKOS	Końcówki proste z nakrętką gwint metryczny – odmiana ciężka	6
DKOS90	Końcówki kątowe 90° z nakrętką gwint metryczny – odmiana ciężka	6
DKOS45	Końcówki kątowe 45° z nakrętką gwint metryczny – odmiana ciężka	6
CES	Końcówki proste gwint zewnętrzny metryczny – odmiana ciężka	7
RNM	Końcówki oczkowe metryczne	7
DKR	Końcówki proste z nakrętką gwint calowy BSP	8
DKR90	Końcówki kątowe 90° z nakrętką gwint calowy BSP	8
DKR45	Końcówki kątowe 45° z nakrętką gwint calowy BSP	9
AGR	Końcówki proste gwint zewnętrzny calowy BSP	9
DKJ	Końcówki proste z nakrętką gwint calowy UNF	10
DKJ90	Końcówki kątowe 90° z nakrętką gwint calowy UNF	10
DKJ45	Końcówki kątowe 45° z nakrętką gwint calowy UNF	11
AGJ	Końcówki proste gwint zewnętrzny calowy UNF	11
AGN	Końcówki proste gwint zewnętrzny calowy stożkowy NPT	12
RNR	Końcówki oczkowe calowe	12
DKORFS	Końcówki proste z nakrętką (płaskie) gwint UNF (ORFS)	13
DKORFS90	Końcówki kątowe 90° z nakrętką (płaskie) gwint UNF (ORFS)	13
DKORFS45	Końcówki kątowe 45° z nakrętką (płaskie) gwint UNF (ORFS)	13
AGORFS	Końcówki proste gwint zewnętrzny UNF (ORFS)	14
SFL	Końcówki proste flanszowe 3000 PSI	15
SFL90	Końcówki kątowe 90° flanszowe 3000 PSI	15
SFL45	Końcówki kątowe 45° flanszowe 3000 PSI	15
SFS	Końcówki proste flanszowe 6000 PSI	16
SFS90	Końcówki kątowe 90° flanszowe 6000 PSI	16
SFS45	Końcówki kątowe 45° flanszowe 6000 PSI	16
SFSC	Końcówki proste flanszowe SUPERCAT	17
SFSC90	Końcówki kątowe 90° flanszowe SUPERCAT	17
SFSC45	Końcówki kątowe 45° flanszowe SUPERCAT	17
KL	Końcówki proste lancy do maszyn myjących	18
ZS	Złącza stałe do węży	18
KN	Końcówki proste z nakrętką do maszyn myjących	18
	Tabela rozpoznawania gwintów	19
	Tabela rozpoznawania gwintów c.d.	20
	Orientacyjna tabela zakuwania dla tulei uniwersalnych	21

O 1/2SN

Oprawka / tuleja do wężu 1SN-R1AT-2SN-R2AT-2SC

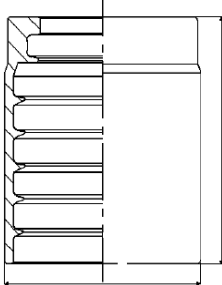

mm	cal	Typ węża	Kod
6	1/4"	1SN-2SN	*O 06 U
8	5/16"	1SN-2SN	*O 08 U
10	3/8"	1SN-2SN	*O 10 U
12	1/2"	1SN-2SN	*O 12 U
16	5/8"	1SN-2SN	*O 16 U
20	3/4"	1SN-2SN	*O 20 U
25	1"	1SN-2SN	*O 25 U
32	1.1/4"	1SN-2SN	*O 32 U
40	1.1/2"	1SN-2SN	*O 40 U
50	2"	1SN-2SN	*O 50 U

O 4SP

Oprawka / tuleja do wężu 4SP

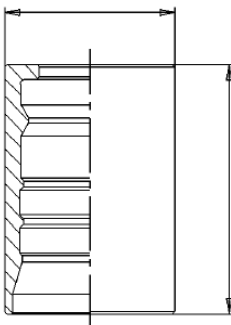

mm	cal	Typ węża	Kod
10	3/8"	4SP	*O 4 10
12	1/2"	4SP	*O 4 12
16	5/8"	4SP	*O 4 16
20	3/4"	4SP	*O 4 20
25	1"	4SP	*O 4 25
32	1.1/4"	4SP	*O 4 32
40	1.1/2"	4SP	*O 4 40
50	2"	4SP	*O 4 50

O 4SH

Oprawka / tuleja do wężu 4SH

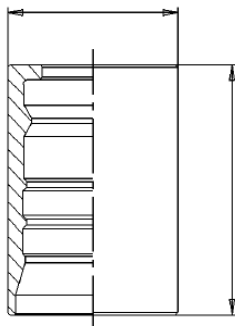

mm	cal	Typ węża	Kod
20	3/4"	4SH	*O 4 20 SH
25	1"	4SH	*O 4 25 SH
32	1.1/4"	4SH	*O 4 32 SH
40	1.1/2"	4SH	*O 4 40 SH
50	2"	4SH	*O 4 50 SH

DKOL

Końcówki proste z nakrętką gwint metryczny – odmiana lekka

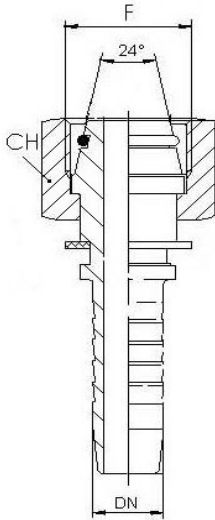

mm	cal	Gwint F	R	Klucz CH	Kod
5	3/16"	12x1,5	6	14	*05 DKOL 12x1,5
6	1/4"	12x1,5	6	14	*06 DKOL 12x1,5
6	1/4"	14x1,5	8	17	*06 DKOL 14x1,5
6	1/4"	16x1,5	10	19	*06 DKOL 16x1,5
6	1/4"	18x1,5	12	22	*06 DKOL 18x1,5
8	5/16"	16x1,5	10	19	*08 DKOL 16x1,5
8	5/16"	18x1,5	12	22	*08 DKOL 18x1,5
8	5/16"	22x1,5	15	27	*08 DKOL 22x1,5
10	3/8"	16x1,5	10	19	*10 DKOL 16x1,5
10	3/8"	18x1,5	12	22	*10 DKOL 18x1,5
10	3/8"	22x1,5	15	27	*10 DKOL 22x1,5
12	1/2"	18x1,5	12	22	*12 DKOL 18x1,5
12	1/2"	22x1,5	15	27	*12 DKOL 22x1,5
12	1/2"	26x1,5	18	32	*12 DKOL 26x1,5
12	1/2"	27x2	18	32	*12 DKOL 27x2
16	5/8"	22x1,5	15	27	*16 DKOL 22x1,5
16	5/8"	26x1,5	18	32	*16 DKOL 26x1,5
16	5/8"	27x2	18	32	*16 DKOL 27x2
20	3/4"	30x2	22	36	*20 DKOL 30x2
25	1"	36x2	28	41	*25 DKOL 36x2
32	1.1/4"	45x2	35	50	*32 DKOL 45x2
40	1.1/2"	52x2	42	60	*40 DKOL 52x2

DKOL90

Końcówki katowe 90° z nakrętką gwint metryczny – odmiana lekka

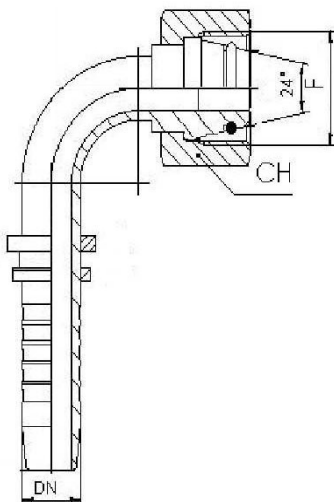

mm	cal	Gwint F	R	Klucz CH	Kod
5	3/16"	12x1,5	6	14	*05 DKOL90 12x1,5
6	1/4"	12x1,5	6	14	*06 DKOL90 12x1,5
6	1/4"	14x1,5	8	17	*06 DKOL90 14x1,5
6	1/4"	16x1,5	10	19	*06 DKOL90 16x1,5
6	1/4"	18x1,5	12	22	*06 DKOL90 18x1,5
8	5/16"	16x1,5	10	19	*08 DKOL90 16x1,5
8	5/16"	18x1,5	12	22	*08 DKOL90 18x1,5
8	5/16"	22x1,5	15	27	*08 DKOL90 22x1,5
10	3/8"	16x1,5	10	19	*10 DKOL90 16x1,5
10	3/8"	18x1,5	12	22	*10 DKOL90 18x1,5
10	3/8"	22x1,5	15	27	*10 DKOL90 22x1,5
12	1/2"	18x1,5	12	22	*12 DKOL90 18x1,5
12	1/2"	22x1,5	15	27	*12 DKOL90 22x1,5
12	1/2"	26x1,5	18	32	*12 DKOL90 26x1,5
12	1/2"	27x2	18	32	*12 DKOL90 27x2
16	5/8"	22x1,5	15	27	*16 DKOL90 22x1,5
16	5/8"	26x1,5	18	32	*16 DKOL90 26x1,5
16	5/8"	27x2	18	32	*16 DKOL90 27x2
20	3/4"	30x2	22	36	*20 DKOL90 30x2
25	1"	36x2	28	41	*25 DKOL90 36x2
32	1.1/4"	45x2	35	50	*32 DKOL90 45x2
40	1.1/2"	52x2	42	60	*40 DKOL90 52x2

DKOL45

Końcówki kątowe 45° z nakrętką gwint metryczny – odmiana lekka

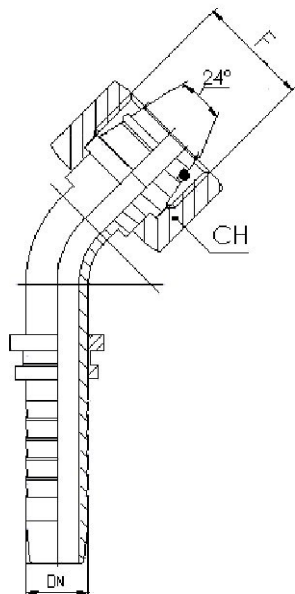

mm	cal	Gwint F	R	Klucz CH	Kod
5	3/16"	12x1,5	6	14	*05 DKOL45 12x1,5
6	1/4"	12x1,5	6	14	*06 DKOL45 12x1,5
6	1/4"	14x1,5	8	17	*06 DKOL45 14x1,5
6	1/4"	16x1,5	10	19	*06 DKOL45 16x1,5
6	1/4"	18x1,5	12	22	*06 DKOL45 18x1,5
8	5/16"	16x1,5	10	19	*08 DKOL45 16x1,5
8	5/16"	18x1,5	12	22	*08 DKOL45 18x1,5
8	5/16"	22x1,5	15	27	*08 DKOL45 22x1,5
10	3/8"	16x1,5	10	19	*10 DKOL45 16x1,5
10	3/8"	18x1,5	12	22	*10 DKOL45 18x1,5
10	3/8"	22x1,5	15	27	*10 DKOL45 22x1,5
12	1/2"	18x1,5	12	22	*12 DKOL45 18x1,5
12	1/2"	22x1,5	15	27	*12 DKOL45 22x1,5
12	1/2"	26x1,5	18	32	*12 DKOL45 26x1,5
12	1/2"	27x2	18	32	*12 DKOL45 27x2
16	5/8"	22x1,5	15	27	*16 DKOL45 22x1,5
16	5/8"	26x1,5	18	32	*16 DKOL45 26x1,5
16	5/8"	27x2	18	32	*16 DKOL45 27x2
20	3/4"	30x2	22	36	*20 DKOL45 30x2
25	1"	36x2	28	41	*25 DKOL45 36x2
32	1.1/4"	45x2	35	50	*32 DKOL45 45x2
40	1.1/2"	52x2	42	60	*40 DKOL45 52x2

CEL

Końcówki proste gwint zewnętrzny metryczny – odmiana lekka

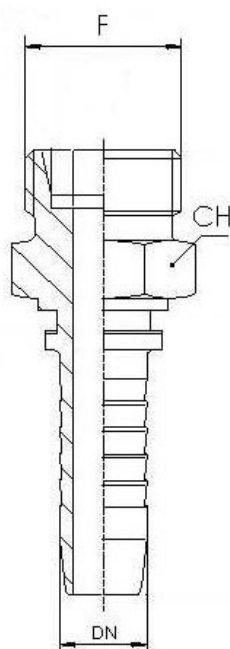

mm	cal	Gwint F	R	Klucz CH	Kod
5	3/16"	12x1,5	6	12	*05 CEL 12x1,5
6	1/4"	12x1,5	6	12	*06 CEL 12x1,5
6	1/4"	14x1,5	8	14	*06 CEL 14x1,5
6	1/4"	16x1,5	10	17	*06 CEL 16x1,5
6	1/4"	18x1,5	12	19	*06 CEL 18x1,5
8	5/16"	16x1,5	10	17	*08 CEL 16x1,5
8	5/16"	18x1,5	12	19	*08 CEL 18x1,5
8	5/16"	22x1,5	15	24	*08 CEL 22x1,5
10	3/8"	16x1,5	10	17	*10 CEL 16x1,5
10	3/8"	18x1,5	12	19	*10 CEL 18x1,5
10	3/8"	22x1,5	15	24	*10 CEL 22x1,5
12	1/2"	18x1,5	12	19	*12 CEL 18x1,5
12	1/2"	22x1,5	15	24	*12 CEL 22x1,5
12	1/2"	26x1,5	18	27	*12 CEL 26x1,5
12	1/2"	27x2	18	28	*12 CEL 27x2
16	5/8"	22x1,5	15	24	*16 CEL 22x1,5
16	5/8"	26x1,5	18	27	*16 CEL 26x1,5
16	5/8"	27x2	18	28	*16 CEL 27x2
20	3/4"	30x2	22	32	*20 CEL 30x2
25	1"	36x2	28	41	*25 CEL 36x2
32	1.1/4"	45x2	35	46	*32 CEL 45x2
40	1.1/2"	52x2	42	55	*40 CEL 52x2

DKOS

Końcówki proste z nakrętką gwint metryczny – odmiana ciężka

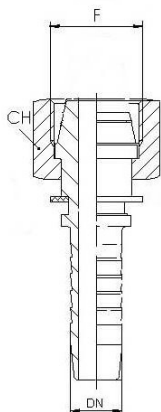

mm	cal	Gwint F	R	Klucz CH	Kod
6	1/4"	14x1,5	6	17	*06 DKOS 14x1,5
6	1/4"	16x1,5	8	19	*06 DKOS 16x1,5
6	1/4"	18x1,5	10	22	*06 DKOS 18x1,5
8	5/16"	18x1,5	10	22	*08 DKOS 18x1,5
8	5/16"	20x1,5	12	24	*08 DKOS 20x1,5
10	3/8"	20x1,5	12	24	*10 DKOS 20x1,5
10	3/8"	22x1,5	14	27	*10 DKOS 22x1,5
12	1/2"	24x1,5	16	30	*12 DKOS 24x1,5
16	5/8"	30x2	20	36	*16 DKOS 30x2
20	3/4"	30x2	20	36	*20 DKOS 30x2
20	3/4"	36x2	25	46	*20 DKOS 36x2
25	1"	36x2	25	46	*25 DKOS 36x2
25	1"	42x2	30	50	*25 DKOS 42x2
32	1.1/4"	52x2	38	60	*32 DKOS 52x2

DKOS90

Końcówki kątowe 90° z nakrętką gwint metryczny – odmiana ciężka

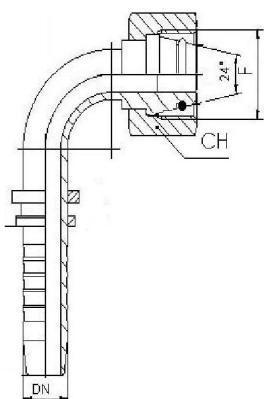

mm	cal	Gwint F	R	Klucz CH	Kod
6	1/4"	14x1,5	6	17	*06 DKOS90 14x1,5
6	1/4"	16x1,5	8	19	*06 DKOS90 16x1,5
6	1/4"	18x1,5	10	22	*06 DKOS90 18x1,5
8	5/16"	18x1,5	10	22	*08 DKOS90 18x1,5
8	5/16"	20x1,5	12	24	*08 DKOS90 20x1,5
10	3/8"	20x1,5	12	24	*10 DKOS90 20x1,5
10	3/8"	22x1,5	14	27	*10 DKOS90 22x1,5
12	1/2"	24x1,5	16	30	*12 DKOS90 24x1,5
16	5/8"	30x2	20	36	*16 DKOS90 30x2
20	3/4"	30x2	20	36	*20 DKOS90 30x2
20	3/4"	36x2	25	46	*20 DKOS90 36x2
25	1"	36x2	25	46	*25 DKOS90 36x2
25	1"	42x2	30	50	*25 DKOS90 42x2
32	1.1/4"	52x2	38	60	*32 DKOS90 52x2

DKOS45

Końcówki kątowe 45° z nakrętką gwint metryczny – odmiana ciężka

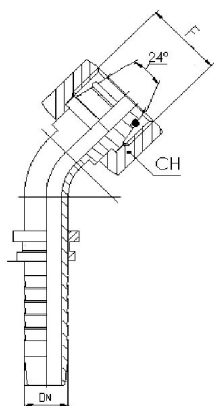

mm	cal	Gwint F	R	Klucz CH	Kod
6	1/4"	14x1,5	6	17	*06 DKOS45 14x1,5
6	1/4"	16x1,5	8	19	*06 DKOS45 16x1,5
6	1/4"	18x1,5	10	22	*06 DKOS45 18x1,5
8	5/16"	18x1,5	10	22	*08 DKOS45 18x1,5
8	5/16"	20x1,5	12	24	*08 DKOS45 20x1,5
10	3/8"	20x1,5	12	24	*10 DKOS45 20x1,5
10	3/8"	22x1,5	14	27	*10 DKOS45 22x1,5
12	1/2"	24x1,5	16	30	*12 DKOS45 24x1,5
16	5/8"	30x2	20	36	*16 DKOS45 30x2
20	3/4"	30x2	20	36	*20 DKOS45 30x2
20	3/4"	36x2	25	46	*20 DKOS45 36x2
25	1"	36x2	25	46	*25 DKOS45 36x2
25	1"	42x2	30	50	*25 DKOS45 42x2
32	1.1/4"	52x2	38	60	*32 DKOS45 52x2

CES

Końcówki proste gwint zewnętrzny metryczny – odmiana ciężka

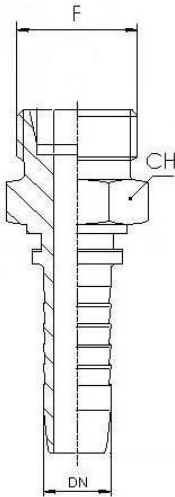

mm	cal	Gwint F	R	Klucz CH	Kod
6	1/4"	14x1,5	6	17	*06 CES 14x1,5
6	1/4"	16x1,5	8	19	*06 CES 16x1,5
6	1/4"	18x1,5	10	19	*06 CES 18x1,5
8	5/16"	18x1,5	10	22	*08 CES 18x1,5
8	5/16"	20x1,5	12	22	*08 CES 20x1,5
10	3/8"	20x1,5	12	24	*10 CES 20x1,5
10	3/8"	22x1,5	14	27	*10 CES 22x1,5
12	1/2"	24x1,5	16	32	*12 CES 24x1,5
16	5/8"	30x2	20	32	*16 CES 30x2
20	3/4"	30x2	20	38	*20 CES 30x2
20	3/4"	36x2	25	38	*20 CES 36x2
25	1"	36x2	25	46	*25 CES 36x2
25	1"	42x2	30	55	*25 CES 42x2
32	1.1/4"	52x2	38	55	*32 CES 52x2

RNM

Końcówki oczkowe metryczne

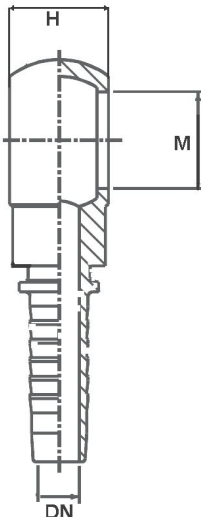

mm	cal	M	H	Kod
6	1/4"	Ø 10	10	*06 RNM 10
6	1/4"	Ø 12	12	*06 RNM 12
6	1/4"	Ø 14	14	*06 RNM 14
6	1/4"	Ø 16	17	*06 RNM 16
6	1/4"	Ø 18	20	*06 RNM 18
8	5/16"	Ø 12	12	*08 RNM 12
8	5/16"	Ø 14	14	*08 RNM 14
8	5/16"	Ø 16	17	*08 RNM 16
8	5/16"	Ø 18	20	*08 RNM 18
10	3/8"	Ø 14	14	*10 RNM 14
10	3/8"	Ø 16	17	*10 RNM 16
10	3/8"	Ø 18	20	*10 RNM 18
10	3/8"	Ø 20	22	*10 RNM 20
12	1/2"	Ø 18	20	*12 RNM 18
12	1/2"	Ø 20	22	*12 RNM 20
12	1/2"	Ø 22	22	*12 RNM 22
16	5/8"	Ø 22	22	*16 RNM 22

DKR

Końcówki proste z nakrętką gwint calowy BSP

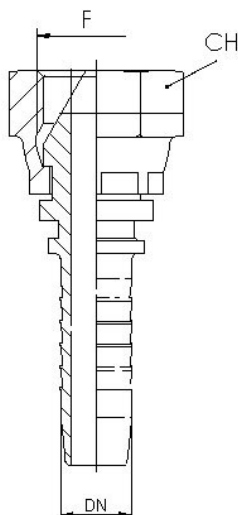

mm	cal	Gwint F	Klucz CH	Kod
5	3/16"	1/4"	19	*05 DKR 1/4"
6	1/4"	1/4"	19	*06 DKR 1/4"
6	1/4"	3/8"	22	*06 DKR 3/8"
8	5/16"	1/4"	19	*08 DKR 1/4"
8	5/16"	3/8"	22	*08 DKR 3/8"
8	5/16"	1/2"	27	*08 DKR 1/2"
10	3/8"	1/4"	19	*10 DKR 1/4"
10	3/8"	3/8"	22	*10 DKR 3/8"
10	3/8"	1/2"	27	*10 DKR 1/2"
12	1/2"	3/8"	22	*12 DKR 3/8"
12	1/2"	1/2"	27	*12 DKR 1/2"
12	1/2"	5/8"	28	*12 DKR 5/8"
12	1/2"	3/4"	32	*12 DKR 3/4"
16	5/8"	1/2"	27	*16 DKR 1/2"
16	5/8"	5/8"	28	*16 DKR 5/8"
16	5/8"	3/4"	32	*16 DKR 3/4"
20	3/4"	3/4"	32	*20 DKR 3/4"
20	3/4"	1"	38	*20 DKR 1"
25	1"	1"	38	*25 DKR 1"
25	1"	1.1/4"	50	*25 DKR 1.1/4"
32	1.1/4"	1.1/2"	50	*32 DKR 1.1/2"
32	1.1/4"	1.1/4"	50	*32 DKR 1.1/4"
40	1.1/2"	1.1/2"	55	*40 DKR 1.1/2"
50	2"	2"	70	*50 DKR 2"

DKR90

Końcówki kątowe 90° z nakrętką gwint calowy BSP

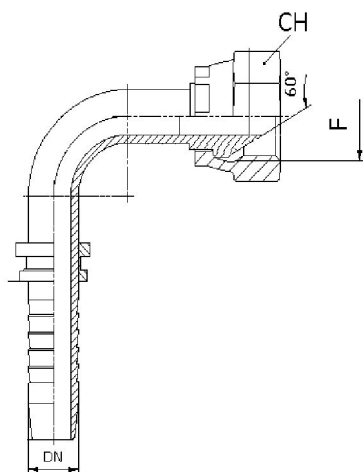

mm	cal	Gwint F	Klucz CH	Kod
6	1/4"	1/4"	19	*06 DKR90 1/4"
6	1/4"	3/8"	22	*06 DKR90 3/8"
8	5/16"	1/4"	19	*08 DKR90 1/4"
8	5/16"	3/8"	22	*08 DKR90 3/8"
8	5/16"	1/2"	27	*08 DKR90 1/2"
10	3/8"	1/4"	19	*10 DKR90 1/4"
10	3/8"	3/8"	22	*10 DKR90 3/8"
10	3/8"	1/2"	27	*10 DKR90 1/2"
12	1/2"	1/2"	27	*12 DKR90 1/2"
12	1/2"	5/8"	28	*12 DKR90 5/8"
12	1/2"	3/4"	32	*12 DKR90 3/4"
16	5/8"	1/2"	27	*16 DKR90 1/2"
16	5/8"	5/8"	28	*16 DKR90 5/8"
16	5/8"	3/4"	32	*16 DKR90 3/4"
20	3/4"	3/4"	32	*20 DKR90 3/4"
20	3/4"	1"	38	*20 DKR90 1"
25	1"	1"	38	*25 DKR90 1"
25	1"	1.1/4"	50	*25 DKR90 1.1/4"
32	1.1/4"	1.1/4"	50	*32 DKR90 1.1/4"
40	1.1/2"	1.1/2"	55	*40 DKR90 1.1/2"
50	2"	2"	70	*50 DKR90 2"

DKR45

Końcówki kątowe 45° z nakrętką gwint calowy BSP

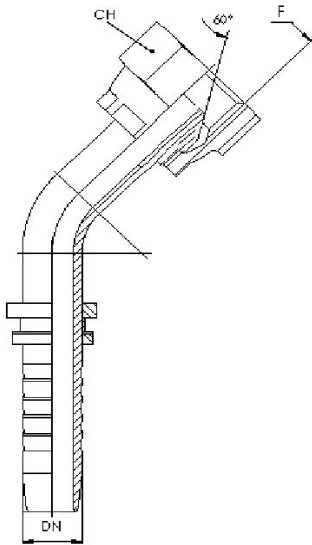

mm	cal	Gwint F	Klucz CH	Kod
6	1/4"	1/4"	19	*06 DKR45 1/4"
6	1/4"	3/8"	22	*06 DKR45 3/8"
8	5/16"	1/4"	19	*08 DKR45 1/4"
8	5/16"	3/8"	22	*08 DKR45 3/8"
8	5/16"	1/2"	27	*08 DKR45 1/2"
10	3/8"	1/4"	19	*10 DKR45 1/4"
10	3/8"	3/8"	22	*10 DKR45 3/8"
10	3/8"	1/2"	27	*10 DKR45 1/2"
12	1/2"	1/2"	27	*12 DKR45 1/2"
12	1/2"	5/8"	28	*12 DKR45 5/8"
12	1/2"	3/4"	32	*12 DKR45 3/4"
16	5/8"	1/2"	27	*16 DKR45 1/2"
16	5/8"	5/8"	28	*16 DKR45 5/8"
16	5/8"	3/4"	32	*16 DKR45 3/4"
20	3/4"	3/4"	32	*20 DKR45 3/4"
20	3/4"	1"	38	*20 DKR45 1"
25	1"	1"	38	*25 DKR45 1"
25	1"	1.1/4"	50	*25 DKR45 1.1/4"
32	1.1/4"	1.1/4"	50	*32 DKR45 1.1/4"
40	1.1/2"	1.1/2"		*40 DKR45 1.1/2"
50	2"	2"		*50 DKR45 2"

AGR

Końcówki proste gwint zewnętrzny calowy BSP

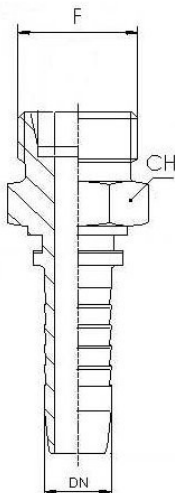

mm	cal	Gwint F	Klucz CH	Kod
5	3/16"	1/4"	19	*05 AGR 1/4"
6	1/4"	1/8"	14	*06 AGR 1/8"
6	1/4"	1/4"	19	*06 AGR 1/4"
6	1/4"	3/8"	22	*06 AGR 3/8"
8	5/16"	1/4"	19	*08 AGR 1/4"
8	5/16"	3/8"	22	*08 AGR 3/8"
8	5/16"	1/2"	27	*08 AGR 1/2"
10	3/8"	1/4"	19	*10 AGR 1/4"
10	3/8"	3/8"	22	*10 AGR 3/8"
10	3/8"	1/2"	27	*10 AGR 1/2"
12	1/2"	3/8"	22	*12 AGR 3/8"
12	1/2"	1/2"	27	*12 AGR 1/2"
12	1/2"	5/8"	28	*12 AGR 5/8"
12	1/2"	3/4"	32	*12 AGR 3/4"
16	5/8"	1/2"	27	*16 AGR 1/2"
16	5/8"	5/8"	28	*16 AGR 5/8"
16	5/8"	3/4"	32	*16 AGR 3/4"
20	3/4"	3/4"	32	*20 AGR 3/4"
20	3/4"	1"	41	*20 AGR 1"
25	1"	1"	41	*25 AGR 1"
25	1"	1.1/4"	50	*25 AGR 1.1/4"
32	1.1/4"	1.1/4"	50	*32 AGR 1.1/4"
40	1.1/2"	1.1/2"	55	*40 AGR 1.1/2"
50	2"	2"	70	*50 AGR 2"

DKJ

Końcówki proste z nakrętką gwint calowy UNF

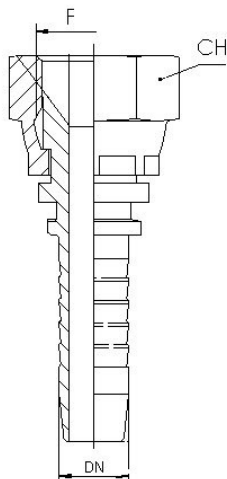

mm	cal	Gwint F	Klucz CH	Kod
6	1/4"	7/16"	15	*06 DKJ 7/16"
6	1/4"	1/2"	17	*06 DKJ 1/2"
6	1/4"	9/16"	19	*06 DKJ 9/16"
8	5/16"	1/2"	17	*08 DKJ 1/2"
8	5/16"	9/16"	19	*08 DKJ 9/16"
8	5/16"	5/8"	19	*08 DKJ 5/8"
8	5/16"	3/4"	24	*08 DKJ 3/4"
10	3/8"	9/16"	19	*10 DKJ 9/16"
10	3/8"	5/8"	22	*10 DKJ 5/8"
10	3/8"	3/4"	24	*10 DKJ 3/4"
10	3/8"	7/8"	27	*10 DKJ 7/8"
12	1/2"	3/4"	24	*12 DKJ 3/4"
12	1/2"	7/8"	27	*12 DKJ 7/8"
12	1/2"	1.1/16"	32	*12 DKJ 1.1/16"
16	5/8"	7/8"	27	*16 DKJ 7/8"
16	5/8"	1.1/16"	32	*16 DKJ 1.1/16"
20	3/4"	1.1/16"	32	*20 DKJ 1.1/16"
20	3/4"	1.3/16"	36	*20 DKJ 1.3/16"
20	3/4"	1.5/16"	41	*20 DKJ 1.5/16"
25	1"	1.5/16"	41	*25 DKJ 1.5/16"
25	1"	1.5/8"	50	*25 DKJ 1.5/8"
32	1.1/4"	1.5/8"	50	*32 DKJ 1.5/8"
32	1.1/4"	1.7/8"	55	*32 DKJ 1.7/8"
40	1.1/2"	1.7/8"	55	*40 DKJ 1.7/8"
50	2"	2.1/2"	70	*50 DKJ 2.1/2"

DKJ90

Końcówki kątowe 90° z nakrętką gwint calowy UNF

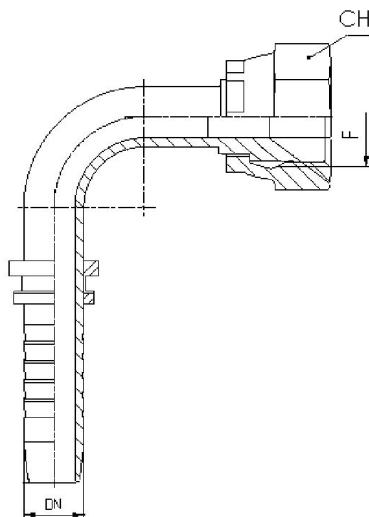

mm	cal	Gwint F	Klucz CH	Kod
6	1/4"	7/16"	15	*06 DKJ90 7/16"
6	1/4"	1/2"	17	*06 DKJ90 1/2"
6	1/4"	9/16"	19	*06 DKJ90 9/16"
8	5/16"	1/2"	17	*08 DKJ90 1/2"
8	5/16"	9/16"	19	*08 DKJ90 9/16"
8	5/16"	3/4"	24	*08 DKJ90 3/4"
10	3/8"	9/16"	19	*10 DKJ90 9/16"
10	3/8"	5/8"	22	*10 DKJ90 5/8"
10	3/8"	3/4"	24	*10 DKJ90 3/4"
10	3/8"	7/8"	27	*10 DKJ90 7/8"
12	1/2"	3/4"	24	*12 DKJ90 3/4"
12	1/2"	7/8"	27	*12 DKJ90 7/8"
12	1/2"	1.1/16"	32	*12 DKJ90 1.1/16"
16	5/8"	7/8"	27	*16 DKJ90 7/8"
16	5/8"	1.1/16"	32	*16 DKJ90 1.1/16"
20	3/4"	1.1/16"	32	*20 DKJ90 1.1/16"
20	3/4"	1.3/16"	36	*20 DKJ90 1.3/16"
20	3/4"	1.5/16"	41	*20 DKJ90 1.5/16"
25	1"	1.5/16"	41	*25 DKJ90 1.5/16"
25	1"	1.5/8"	50	*25 DKJ90 1.5/8"
32	1.1/4"	1.5/8"	50	*32 DKJ90 1.5/8"
32	1.1/4"	1.7/8"	55	*32 DKJ90 1.7/8"
40	1.1/2"	1.7/8"	55	*40 DKJ90 1.7/8"
50	2"	2.1/2"	70	*50 DKJ90 2.1/2"

DKJ45

Końcówki kątowe 45° z nakrętką gwint calowy UNF

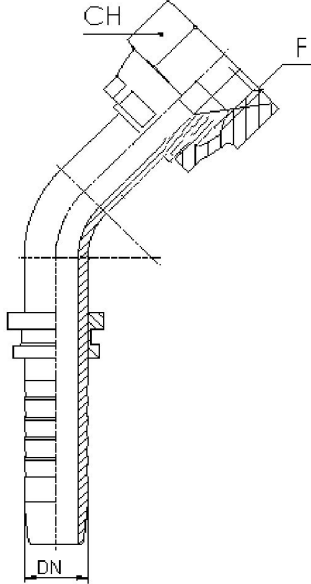

mm	cal	Gwint F	Klucz CH	Kod
6	1/4"	7/16"	15	*06 DKJ45 7/16"
6	1/4"	1/2"	17	*06 DKJ45 1/2"
6	1/4"	9/16"	19	*06 DKJ45 9/16"
8	5/16"	1/2"	17	*08 DKJ45 1/2"
8	5/16"	9/16"	19	*08 DKJ45 9/16"
8	5/16"	3/4"	24	*08 DKJ45 3/4"
10	3/8"	9/16"	19	*10 DKJ45 9/16"
10	3/8"	5/8"	22	*10 DKJ45 5/8"
10	3/8"	3/4"	24	*10 DKJ45 3/4"
10	3/8"	7/8"	27	*10 DKJ45 7/8"
12	1/2"	3/4"	24	*12 DKJ45 3/4"
12	1/2"	7/8"	27	*12 DKJ45 7/8"
12	1/2"	1.1/16"	32	*12 DKJ45 1.1/16"
16	5/8"	7/8"	27	*16 DKJ45 7/8"
16	5/8"	1.1/16"	32	*16 DKJ45 1.1/16"
20	3/4"	1.1/16"	32	*20 DKJ45 1.1/16"
20	3/4"	1.3/16"	36	*20 DKJ45 1.3/16"
20	3/4"	1.5/16"	41	*20 DKJ45 1.5/16"
25	1"	1.5/16"	41	*25 DKJ45 1.5/16"
25	1"	1.5/8"	50	*25 DKJ45 1.5/8"
32	1.1/4"	1.5/8"	50	*32 DKJ45 1.5/8"
32	1.1/4"	1.7/8"	55	*32 DKJ45 1.7/8"
40	1.1/2"	1.7/8"	55	*40 DKJ45 1.7/8"
50	2"	2.1/2"	70	*50 DKJ45 2.1/2"

AGJ

Końcówki proste gwint zewnętrzny calowy UNF

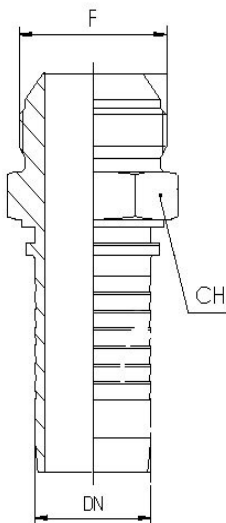

mm	cal	Gwint F	Klucz CH	Kod
6	1/4"	7/16"	12	*06 AGJ 7/16"
6	1/4"	1/2"	15	*06 AGJ 1/2"
6	1/4"	9/16"	14,15	*06 AGJ 9/16"
8	5/16"	1/2"	15	*08 AGJ 1/2"
8	5/16"	9/16"	15,17	*08 AGJ 9/16"
8	5/16"	3/4"	19	*08 AGJ 3/4"
10	3/8"	9/16"	15,17	*10 AGJ 9/16"
10	3/8"	5/8"	17	*10 AGJ 5/8"
10	3/8"	3/4"	19,22	*10 AGJ 3/4"
10	3/8"	7/8"	24	*10 AGJ 7/8"
12	1/2"	3/4"	19,22	*12 AGJ 3/4"
12	1/2"	7/8"	24	*12 AGJ 7/8"
12	1/2"	1.1/16"	27	*12 AGJ 1.1/16"
16	5/8"	7/8"	24	*16 AGJ 7/8"
16	5/8"	1.1/16"	27	*16 AGJ 1.1/16"
20	3/4"	1.1/16"	27	*20 AGJ 1.1/16"
20	3/4"	1.3/16"	32	*20 AGJ 1.3/16"
20	3/4"	1.5/16"	32	*20 AGJ 1.5/16"
25	1"	1.5/16"	34,36	*25 AGJ 1.5/16"
25	1"	1.5/8"	34	*25 AGJ 1.5/8"
32	1.1/4"	1.5/8"	42	*32 AGJ 1.5/8"
32	1.1/4"	1.7/8"	50	*32 AGJ 1.7/8"
40	1.1/2"	1.7/8"	50	*40 AGJ 1.7/8"
50	2"	2.1/2"	65	*50 AGJ 2.1/2"

AGN

Końcówki proste gwint zewnętrzny całowy stożkowy NPT

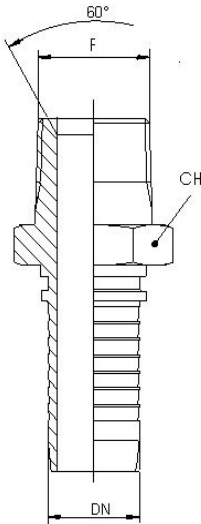

mm	cal	Gwint F	Klucz CH	Kod
6	1/4"	1/4"	15	*06 AGN 1/4"
10	3/8"	3/8"	19	*10 AGN 3/8"
12	1/2"	1/2"	22	*12 AGN 1/2"
16	5/8"	5/8"	24	*16 AGN 5/8"
20	3/4"	3/4"	27	*20 AGN 3/4"
25	1"	1"	36	*25 AGN 1"
32	1.1/4"	1.1/4"	46	*32 AGN 1.1/4"
40	1.1/2"	1.1/2"	50	*40 AGN 1.1/2"
50	2"	2"	65	*50 AGN 2"

RNR

Końcówki oczkowe całowe

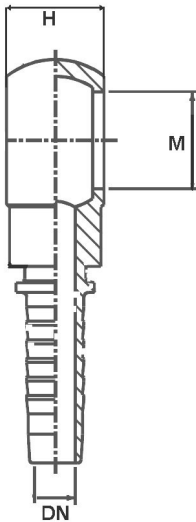

mm	cal	Gwint F	H	Kod
6	1/4"	1/4"	14	*06 RNR 1/4"
6	1/4"	3/8"	15	*06 RNR 3/8"
8	5/16"	1/4"	14	*08 RNR 1/4"
8	5/16"	3/8"	15	*08 RNR 3/8"
8	5/16"	1/2"	19	*08 RNR 1/2"
10	3/8"	3/8"	15	*10 RNR 3/8"
12	1/2"	1/2"	19	*12 RNR 1/2"
19	3/4"	3/4"	26	*19 RNR 3/4"

DKORFS

Końcówki proste z nakrętką (płaskie) gwint UNF (ORFS)

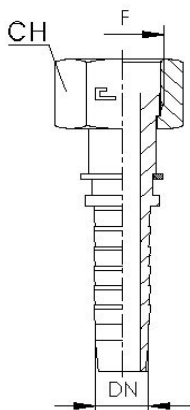

mm	cal	Gwint F	Klucz CH	Kod
6	1/4"	9/16"-18	17	*06 DKORFS 9/16"
6	1/4"	11/16"-16	22	*06 DKORFS 11/16"
8	5/16"	11/16"-16	22	*08 DKORFS 11/16"
10	3/8"	11/16"-16	22	*10 DKORFS 11/16"
10	3/8"	13/16"-16	24	*10 DKORFS 13/16"
12	1/2"	13/16"-16	24	*12 DKORFS 13/16"
12	1/2"	1"-14	30	*12 DKORFS 1"
12	1/2"	1.3/16"-12	36	*12 DKORFS 1.3/16"
16	5/8"	1"-14	30	*16 DKORFS 1"
16	5/8"	1.3/16"-12	36	*16 DKORFS 1.3/16"
20	3/4"	1.3/16"-12	36	*20 DKORFS 1.3/16"
20	3/4"	1.7/16"-12	41	*20 DKORFS 1.7/16"
25	1"	1.7/16"-12	41	*25 DKORFS 1.7/16"
32	1.1/4"	1.11/16"-12	50	*32 DKORFS 1.11/16"
40	1.1/2"	2"-12	60	*32 DKORFS 2"

DKORFS90

Końcówki kątowe 90° z nakrętką (płaskie) gwint UNF (ORFS)

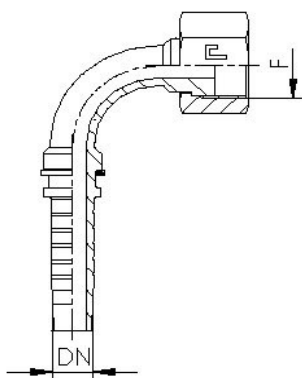

mm	cal	Gwint F	Klucz CH	Kod
6	1/4"	9/16"-18	17	*06 DKORFS90 9/16"
6	1/4"	11/16"-16	22	*06 DKORFS90 11/16"
8	5/16"	11/16"-16	22	*08 DKORFS90 11/16"
10	3/8"	11/16"-16	22	*10 DKORFS90 11/16"
10	3/8"	13/16"-16	24	*10 DKORFS90 13/16"
12	1/2"	13/16"-16	24	*12 DKORFS90 13/16"
12	1/2"	1"-14	30	*12 DKORFS90 1"
12	1/2"	1.3/16"-12	36	*12 DKORFS90 1.3/16"
16	5/8"	1"-14	30	*16 DKORFS90 1"
16	5/8"	1.3/16"-12	36	*16 DKORFS90 1.3/16"
20	3/4"	1.3/16"-12	36	*20 DKORFS90 1.3/16"
20	3/4"	1.7/16"-12	41	*20 DKORFS90 1.7/16"
25	1"	1.7/16"-12	41	*25 DKORFS90 1.7/16"
32	1.1/4"	1.11/16"-12	50	*32 DKORFS90 1.11/16"
40	1.1/2"	2"-12	60	*32 DKORFS90 2"

DKORFS45

Końcówki kątowe 45° z nakrętką (płaskie) gwint UNF (ORFS)

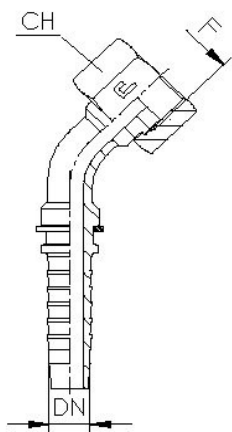

mm	cal	Gwint F	Klucz CH	Kod
6	1/4"	9/16"-18	17	*06 DKORFS45 9/16"
6	1/4"	11/16"-16	22	*06 DKORFS45 11/16"
8	5/16"	11/16"-16	22	*08 DKORFS45 11/16"
10	3/8"	11/16"-16	22	*10 DKORFS45 11/16"
10	3/8"	13/16"-16	24	*10 DKORFS45 13/16"
12	1/2"	13/16"-16	24	*12 DKORFS45 13/16"
12	1/2"	1"-14	30	*12 DKORFS45 1"
12	1/2"	1.3/16"-12	36	*12 DKORFS45 1.3/16"
16	5/8"	1"-14	30	*16 DKORFS45 1"
16	5/8"	1.3/16"-12	36	*16 DKORFS45 1.3/16"
20	3/4"	1.3/16"-12	36	*20 DKORFS45 1.3/16"
20	3/4"	1.7/16"-12	41	*20 DKORFS45 1.7/16"
25	1"	1.7/16"-12	41	*25 DKORFS45 1.7/16"
32	1.1/4"	1.11/16"-12	50	*32 DKORFS45 1.11/16"
40	1.1/2"	2"-12	60	*32 DKORFS45 2"

AGORFS

Końcówki proste gwint zewnętrzny UNF (ORFS)

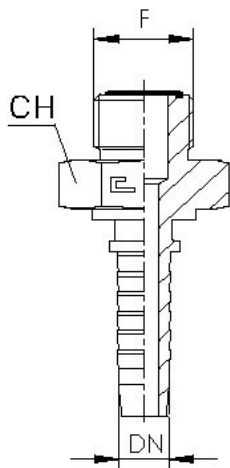

mm	cal	Gwint F	Klucz CH	Kod
6	1/4"	9/16"-18	17	*06 AGORFS 9/16"
6	1/4"	11/16"-16	19	*06 AGORFS 11/16"
8	5/16"	11/16"-16	19	*08 AGORFS 11/16"
10	3/8"	11/16"-16	19	*10 AGORFS 11/16"
10	3/8"	13/16"-16	22	*10 AGORFS 13/16"
12	1/2"	13/16"-16	22	*12 AGORFS 13/16"
12	1/2"	1"-14	27	*12 AGORFS 1"
12	1/2"	1.3/16"-12	27	*12 AGORFS 1.3/16"
16	5/8"	1"-14	27	*16 AGORFS 1"
16	5/8"	1.3/16"-12	32	*16 AGORFS 1.3/16"
20	3/4"	1.3/16"-12	32	*20 AGORFS 1.3/16"
20	3/4"	1.7/16"-12	41	*20 AGORFS 1.7/16"
25	1"	1.7/16"-12	41	*25 AGORFS 1.7/16"
32	1.1/4"	1.11/16"-12	46	*32 AGORFS 1.11/16"
40	1.1/2"	2"-12	55	*32 AGORFS 2"

SFL

Końcówki proste flanszowe 3000 PSI

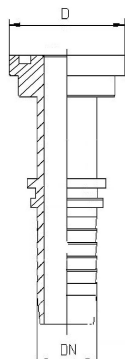

mm	cal	D	Flansza	Kod
12	1/2"	30,2	1/2"	*12 SFL 30,2
12	1/2"	38,1	3/4"	*12 SFL 38,1
16	5/8"	38,1	3/4"	*16 SFL 38,1
20	3/4"	38,1	3/4"	*20 SFL 38,1
20	3/4"	44,5	1"	*20 SFL 44,5
25	1"	44,5	1"	*25 SFL 44,5
25	1"	50,8	1.1/4"	*25 SFL 50,8
32	1.1/4"	50,8	1.1/4"	*32 SFL 50,8
32	1.1/4"	60,3	1.1/2"	*32 SFL 60,3
40	1.1/2"	60,3	1.1/2"	*40 SFL 60,3
40	1.1/2"	71,4	2"	*40 SFL 71,4

SFL90

Końcówki kątowe 90° flanszowe 3000 PSI

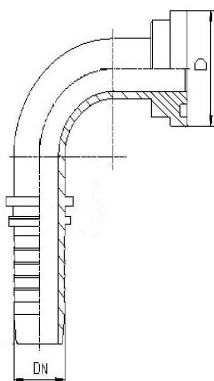

mm	cal	D	Flansza	Kod
12	1/2"	30,2	1/2"	*12 SFL90 30,2
12	1/2"	38,1	3/4"	*12 SFL90 38,1
16	5/8"	38,1	3/4"	*16 SFL90 38,1
20	3/4"	38,1	3/4"	*20 SFL90 38,1
20	3/4"	44,5	1"	*20 SFL90 44,5
25	1"	44,5	1"	*25 SFL90 44,5
25	1"	50,8	1.1/4"	*25 SFL90 50,8
32	1.1/4"	50,8	1.1/4"	*32 SFL90 50,8
32	1.1/4"	60,3	1.1/2"	*32 SFL90 60,3
40	1.1/2"	60,3	1.1/2"	*40 SFL90 60,3
40	1.1/2"	71,4	2"	*40 SFL90 71,4
50	2"	71,4	2"	*50 SFL90 71,4

SFL45

Końcówki kątowe 45° flanszowe 3000 PSI

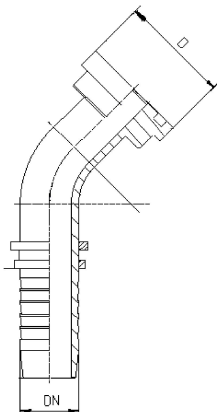

mm	cal	D	Flansza	Kod
12	1/2"	30,2	1/2"	*12 SFL45 30,2
12	1/2"	38,1	3/4"	*12 SFL45 38,1
16	5/8"	38,1	3/4"	*16 SFL45 38,1
20	3/4"	38,1	3/4"	*20 SFL45 38,1
20	3/4"	44,5	1"	*20 SFL45 44,5
25	1"	44,5	1"	*25 SFL45 44,5
25	1"	50,8	1.1/4"	*25 SFL45 50,8
32	1.1/4"	50,8	1.1/4"	*32 SFL45 50,8
32	1.1/4"	60,3	1.1/2"	*32 SFL45 60,3
40	1.1/2"	60,3	1.1/2"	*40 SFL45 60,3
40	1.1/2"	71,4	2"	*40 SFL45 71,4
50	2"	71,4	2"	*50 SFL45 71,4

SFS

Końcówki proste flanszowe 6000 PSI

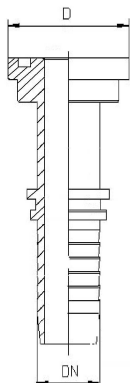

mm	cal	D	Flansza	Kod
12	1/2"	31,7	1/2"	*12 SFS 31,7
12	1/2"	41,3	3/4"	*12 SFS 41,3
16	5/8"	41,3	3/4"	*16 SFS 41,3
20	3/4"	41,3	3/4"	*20 SFS 41,3
20	3/4"	47,6	1"	*20 SFS 47,6
25	1"	47,6	1"	*25 SFS 47,6
25	1"	54,0	1.1/4"	*25 SFS 54,0
32	1.1/4"	54,0	1.1/4"	*32 SFS 54,0
32	1.1/4"	63,5	1.1/2"	*32 SFS 63,5
40	1.1/2"	63,5	1.1/2"	*40 SFS 63,5
40	1.1/2"	79,4	2"	*40 SFS 79,4
50	2"	79,4	2"	*50 SFS 79,4

SFS90

Końcówki kątowe 90° flanszowe 6000 PSI

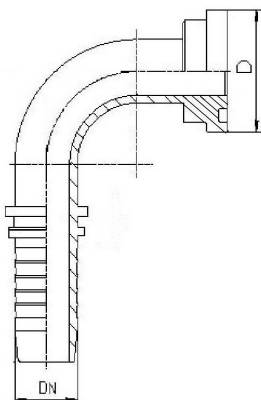

mm	cal	D	Flansza	Kod
12	1/2"	31,7	1/2"	*12 SFS90 31,7
12	1/2"	41,3	3/4"	*12 SFS90 41,3
16	5/8"	41,3	3/4"	*16 SFS90 41,3
20	3/4"	41,3	3/4"	*20 SFS90 41,3
20	3/4"	47,6	1"	*20 SFS90 47,6
25	1"	47,6	1"	*25 SFS90 47,6
25	1"	54,0	1.1/4"	*25 SFS90 54,0
32	1.1/4"	54,0	1.1/4"	*32 SFS90 54,0
32	1.1/4"	63,5	1.1/2"	*32 SFS90 63,5
40	1.1/2"	63,5	1.1/2"	*40 SFS90 63,5
40	1.1/2"	79,4	2"	*40 SFS90 79,4
50	2"	79,4	2"	*50 SFS90 79,4

SFS45

Końcówki kątowe 45° flanszowe 6000 PSI

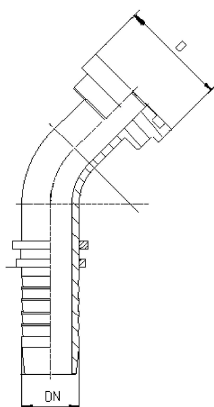

mm	cal	D	Flansza	Kod
12	1/2"	31,7	1/2"	*12 SFS45 31,7
12	1/2"	41,3	3/4"	*12 SFS45 41,3
16	5/8"	41,3	3/4"	*16 SFS45 41,3
20	3/4"	41,3	3/4"	*20 SFS45 41,3
20	3/4"	47,6	1"	*20 SFS45 47,6
25	1"	47,6	1"	*25 SFS45 47,6
25	1"	54,0	1.1/4"	*25 SFS45 54,0
32	1.1/4"	54,0	1.1/4"	*32 SFS45 54,0
32	1.1/4"	63,5	1.1/2"	*32 SFS45 63,5
40	1.1/2"	63,5	1.1/2"	*40 SFS45 63,5
40	1.1/2"	79,4	2"	*40 SFS45 79,4
50	2"	79,4	2"	*50 SFS45 79,4

SFSC

Końcówki proste flanszowe SUPERCAT

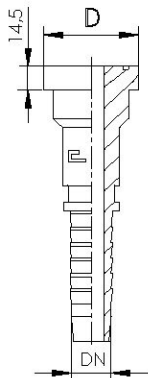

mm	cal	D	Flansza	Kod
20	3/4"	41,3	3/4"	*20 SFSC 41,3
20	3/4"	47,6	1"	*20 SFSC 47,6
25	1"	47,6	1"	*25 SFSC 47,6
25	1"	54,0	1.1/4"	*25 SFSC 54,0
32	1.1/4"	54,0	1.1/4"	*32 SFSC 54,0

SFSC90

Końcówki kątowe 90° flanszowe SUPERCAT

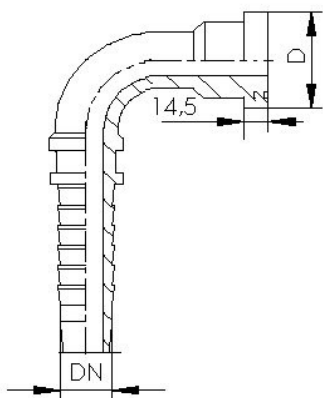

mm	cal	D	Flansza	Kod
20	3/4"	41,3	3/4"	*20 SFSC90 41,3
20	3/4"	47,6	3/4"	*20 SFSC90 47,6
25	1"	47,6	1"	*25 SFSC90 47,6
25	1"	54,0	1"	*25 SFSC90 54,0
32	1.1/4"	54,0	1.1/4"	*32 SFSC90 54,0

SFSC45

Końcówki kątowe 45° flanszowe SUPERCAT

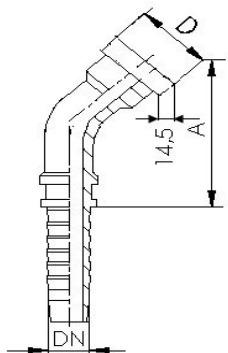

mm	cal	D	Flansza	Kod
20	3/4"	41,3	3/4"	*20 SFSC45 41,3
20	3/4"	47,6	3/4"	*20 SFSC45 47,6
25	1"	47,6	1"	*25 SFSC45 47,6
25	1"	54,0	1"	*25 SFSC45 54,0
32	1.1/4"	54,0	1.1/4"	*32 SFSC45 54,0

KL

Końcówki proste lancy do maszyn myjących

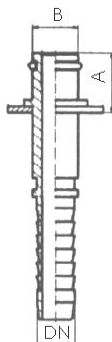

mm	cal	A	B	Kod
6	1/4"	12	10	*06 KL 10
6	1/4"	12	11	*06 KL 11
8	5/16"	12	10	*08 KL 10
8	5/16"	12	11	*08 KL 11

ZS

Złącza stałe do węży

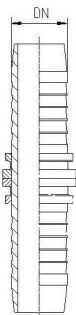

mm	cal	Kod
6	1/4"	*ZS 06
8	5/16"	*ZS 08
10	3/8"	*ZS 10
12	1/2"	*ZS 12
16	5/8"	*ZS 16
20	3/4"	*ZS 20
25	1"	*ZS 25
32	1.1/4"	*ZS 32

KN

Końcówki proste z nakrętką do maszyn myjących

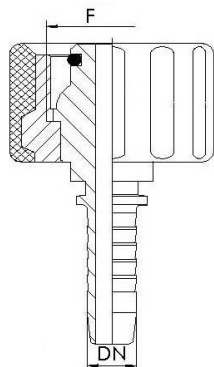

mm	cal	Gwint F	A	Kod
6	1/4"	22x1,5	30,7	*06 KN 10
6	1/4"		30,7	*06 KN 11
8	5/16"	22x1,5	30,7	*08 KN 10
8	5/16"		30,7	*08 KN 11
10	3/8"	22x1,5	30,7	*10 KN 10
10	3/8"		30,7	*10 KN 11

Tabela rozpoznawania gwintów

Średnica [mm]		Skok gwintu	Typ gwintu			
zewnątrznna	wewnątrznna		BSP	Metryczny	UNF, ORFS	NPT
7,8 – 8,0	6,8 – 7,0	1		M8 x 1		
9,3 – 9,7	8,5 – 8,9	28	1/8"			
9,3 – 9,7	8,5 – 8,9	27				1/8"
9,7 – 9,9	8,2 – 8,6	1,5		M10 x 1,5		
9,7 – 9,9	8,7 – 9,1	1		M10 x 1		
10,9 – 11,1	9,7 – 10,0	20			7/16" - 20	
11,6 – 11,9	10,2 – 10,6	1,5		M12 x 1,5		
12,4 – 12,7	11,3 – 11,6	20			1/2" - 20	
12,9 – 13,1	11,4 – 11,9	19	1/4"			
12,9 – 13,1	11,4 – 11,9	18				1/4"
13,6 – 13,9	12,2 – 12,6	1,5		M14 x 1,5		
14,0 – 14,3	12,7 – 13,0	18			9/16" - 18	
15,6 – 15,9	14,2 – 14,6	1,5		M16 x 1,5		
16,3 – 16,6	14,9 – 15,4	19	3/8"			
16,3 – 16,6	14,9 – 15,4	18				3/8"
17,1 – 17,4	15,8 – 16,1	16			11/16" - 16	
17,6 – 17,9	16,2 – 16,6	1,5		M18 x 1,5		
18,7 – 19,0	17,3 – 17,6	16			3/4" - 16	
19,6 – 19,9	18,2 – 18,6	1,5		M20 x 1,5		
20,3 – 20,6	18,9 – 19,3	16			13/16" - 16	
20,5 – 20,9	18,6 – 19,0	14	1/2"			
20,7 – 21,1	18,3 – 18,7	14				1/2"
21,6 – 21,9	20,2 – 20,6	1,5		M22 x 1,5		
22,0 – 22,2	20,2 – 20,5	14			7/8" - 14	
22,6 – 22,9	20,6 – 21,0	14	5/8"			
23,6 – 23,9	22,2 – 22,6	1,5		M24 x 1,5		
25,1 – 25,4	23,4 – 23,8	14			1" - 14	
25,6 – 25,9	24,2 – 24,6	1,5		M26 x 1,5		
26,1 – 26,4	24,1 – 24,5	14	3/4"			
26,3 – 26,7	23,7 – 24,1	14				3/4"
26,6 – 26,9	24,3 – 24,7	12			1.1/16" - 12	
26,6 – 26,9	24,6 – 25,0	2		M27 x 2		
26,6 – 26,9	25,2 – 25,6	1,5		M27 x 1,5		
27,6 – 27,9	26,2 – 26,6	1,5		M28 x 1,5		
29,6 – 29,9	27,4 – 27,8	2		M30 x 2		
29,6 – 29,9	28,2 – 28,6	1,5		M30 x 1,5		
29,8 – 30,1	27,6 – 27,9	12			1.3/16" - 12	
29,8 – 30,2	27,8 – 28,1	14	7/8"			
32,6 – 32,9	30,5 – 30,9	2		M33 x 2		
32,6 – 32,9	31,2 – 31,6	1,5		M33 x 1,5		
33,0 – 33,2	30,3 – 30,8	11	1"			
33,3 – 33,3	30,8 – 31,2	12			1.5/16" - 12	
32,9 – 33,4	30,3 – 30,8	11,5				1"
35,6 – 35,9	33,4 – 33,8	2		M36 x 2		
36,2 – 36,5	34,3 – 34,7	12			1.7/16" - 12	
37,6 – 37,9	34,8 – 35,1	11	1.1/8"			
37,6 – 37,9	36,2 – 36,6	1,5		M38 x 1,5		
40,9 – 41,2	38,7 – 39,1	12			1.5/8" - 12	
41,6 – 41,9	39,4 – 39,8	2		M42 x 2		
41,5 – 41,9	39,0 – 39,5	11	1.1/4"			
41,4 – 42,0	39,2 – 39,6	11,5				1.1/4"
42,5 – 42,8	40,6 – 41,0	12			1.11/16" - 16	
44,6 – 44,9	42,4 – 42,8	2		M45 x 2		

Tabela rozpoznawania gwintów c.d.

Średnica [mm]		Skok gwintu	Typ gwintu			
zewnątrzna	wewnętrzna		BSP	Metryczny	UNF, ORFS	NPT
44,6 – 44,9	43,2 – 43,6	1,5		M45 x 1,5		
47,3 – 47,6	45,1 – 45,5	12			1.7/8" - 12	
47,3 – 47,8	44,8 – 45,3	11			1.1/2"	
47,3 – 47,9	45,1 – 45,5	11,5				1.1/2"
50,5 – 50,8	48,6 – 49,0	12			2" - 12	
51,6 – 51,9	49,4 – 49,6	2		M52 x 2		
59,4 – 59,8	56,5 – 56,8	11	2"			
59,9 – 60,2	56,4 – 56,7	11,5				2"
63,3 – 63,6	61,3 – 61,8	12			2.1/2" - 12	
64,6 – 64,9	62,6 – 63,0	2		M65 x 2		
65,4 – 65,7	62,7 – 63,0	11	2.1/4"			
72,7 – 73,0	68,8 – 69,1	8				2.1/2"
74,9 – 75,2	72,2 – 72,5	11	2.1/2"			
87,5 – 87,9	84,9 – 85,3	11	3"			
88,5 – 88,9	84,7 – 85,1	8				3"
112,6 – 113,0	110,1 – 110,5	11	4"			
113,9 – 114,3	110,2 – 110,6	8				4"
129,4 – 129,8	123,2 – 124,0	6		M130x6		
138,0 – 138,4	135,5 – 135,9	11	5"			

Orientacyjna tabela zakuwania przewodów hydraulicznych dla tulei uniwersalnych

Średnica węża DN mm	Rodzaj węża	
	1 SN	2 SN
6	17,3	18,0
8	19,0	20,3
10	20,8	21,6
12	24,5	25,8
16	27,4	28,1
20	30,4	31,3
25	39,5	40,4